

HOW TO USE YOUR



T

D

C

STEREO  
COLORIST  
CAMERA

# INDEX

Introduction . . . . .	2
Controls, top and front . . . . .	4
Controls, back . . . . .	5
Loading . . . . .	6-7-8
Simplified shooting . . . . .	9
Daylight exposures . . . . .	10-11
Focusing . . . . .	12-13-14
Focusing (critical) . . . . .	15
Stopping action . . . . .	16-17
Picture problems . . . . .	18-19
Colorist flash . . . . .	20-21
Flash exposures . . . . .	22-23
Stereo Planning . . . . .	24-25
Accessories . . . . .	26
Warranty . . . . .	27

## 3-D . . . THE STEREO COLORIST WAY

Now you can capture treasured moments in pictures so real they almost breathe. The matched lenses of the Stereo Colorist camera see things just as your two eyes do, recording them in all the natural brilliance of modern color film. Photos taken the Stereo Colorist way will bring cherished scenes back to life, again and again, whenever you choose to look at them or show them to your friends.

The realism of today's stereo pictures may seem like magic, but it's no trick to

take them with the Stereo Colorist. Its thrilling depth effect is automatic. You make only the basic lens and shutter settings every good camera requires. For average sunny-day shooting with the Stereo Colorist you just set it and forget it, clicking off sparkling pictures without another thought. If you're a fair-weather photographer you can stop right there. You won't have to read beyond the simple loading and shooting instructions that take you to page 9. But your camera

is infinitely more versatile than that.

On the pages that follow you will see how you can use the Stereo Colorist indoors or out, with flash or by daylight, under all sorts of conditions. Whether you shoot the easy way or study each scene to make the most of it, your pictures will always reflect the precision built into the Stereo Colorist camera.

*Good luck, and good shooting!*

**THREE DIMENSION COMPANY**

division of Bell & Howell

# GET ACQUAINTED WITH YOUR TDC STEREO COLORIST CAMERA

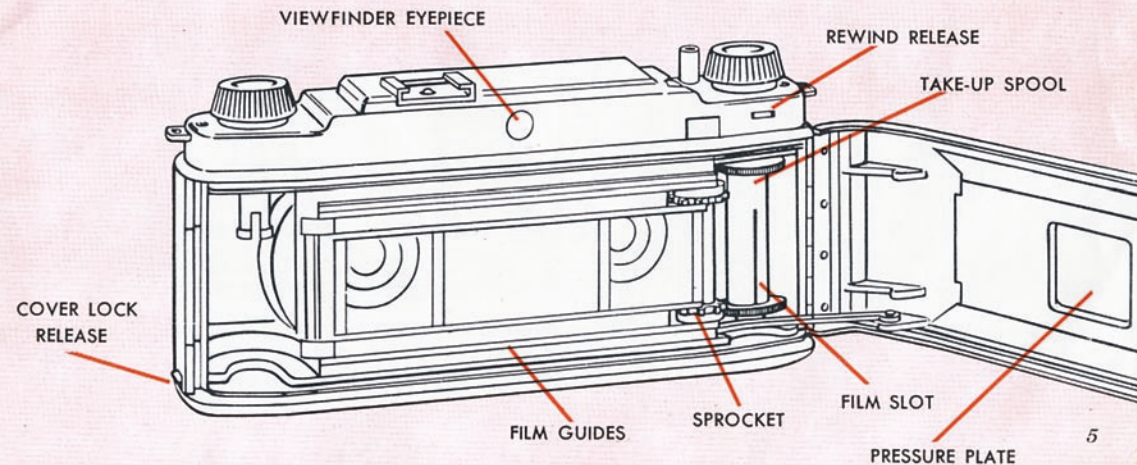
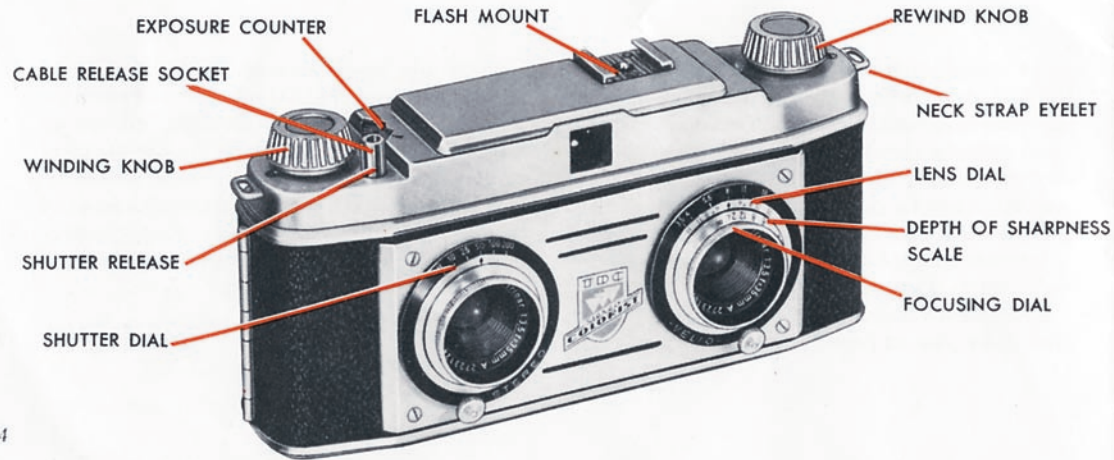

## LOADING



OPEN the camera by pressing cover lock down and swinging cover back.

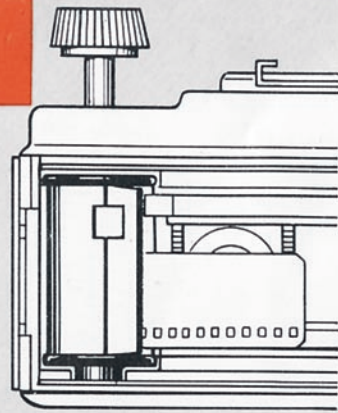

1. LIFT rewind knob as far as it will go and insert film cartridge with leader at bottom.

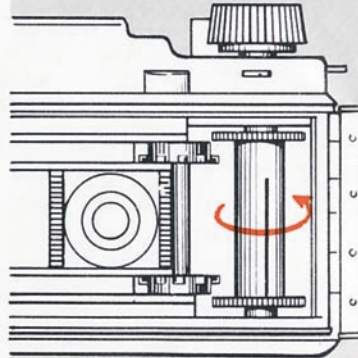

2. COCK shutter by turning sprocket to right until it stops. This ordinarily is done as film passes over it.

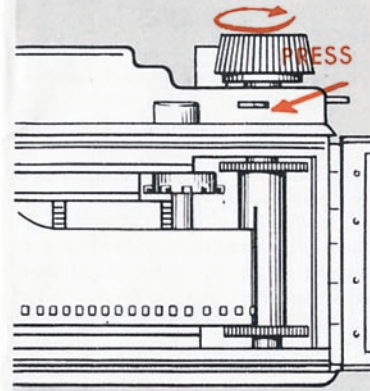

3. HOLD DOWN rewind release while turning take-up spool until film slot is up. Insert leader securely; close back.

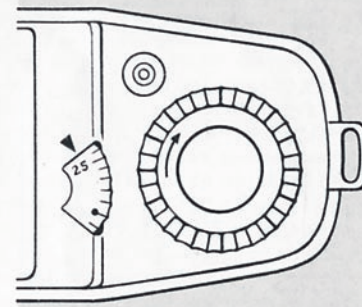

4. TRIP SHUTTER. Turn winding knob in direction of arrow until it stops. If film is engaged properly, film counter dial will rotate.

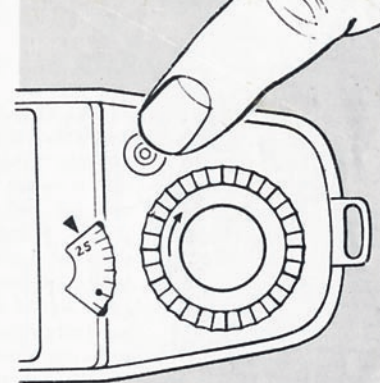

5. TRIP SHUTTER and wind a second time.  
6. TRIP SHUTTER and wind a third time.



7. SET EXPOSURE COUNTER for first picture, placing dot "." opposite arrow. Now you are ready to take pictures. You get 20 with a stereo film load, 16 with a 20-exposure roll and 29 with a 36-exposure cartridge. When counter reaches number of shots for a given film load, last picture is in taking position. After snapping it, film must be rewound into cartridge. CAUTION: Do not force wind knob in an attempt to get an extra exposure. If film pulls loose from spool it will be necessary to remove it in a darkroom.

8. TO REWIND film press rewind release and lift rewind knob. Keep rewind depressed and rewind in direction of arrow. Winding knob will turn backwards as film is rewound. When it stops, give rewind knob about four more turns, open camera back, and remove film cartridge. CAUTION: If rewind release is pressed by accident before roll is finished no harm will be done. Just turn winding knob to take up slack. Keep turning it until it comes to a firm stop. Then you can cock shutter and advance film for next picture.

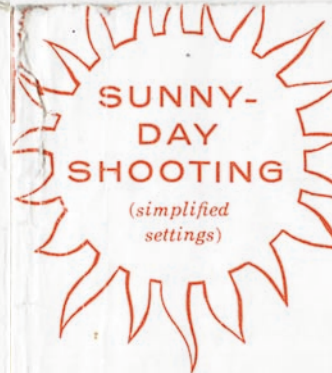
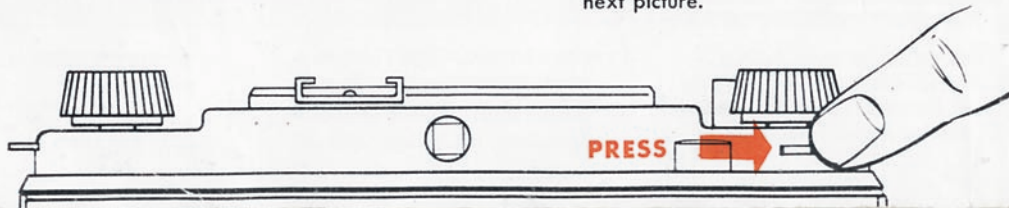

On bright days, you can pre-set the Stereo Colorist and shoot without worrying about exposure. The settings shown below are for average subjects which contain about equal amounts of light and dark colors, in direct sunlight.

1. Turn the shutter dial to place 50 (1/50 second) next to the diamond index point above the right lens of the camera.

2. Set the lens dial halfway between f/5.6 and f/8. This is f/6.3—the best aperture to use in bright sunlight.
3. Turn focusing dial to align 24 (24 feet) with index point above left lens. Everything beyond 12 feet from camera will then be in focus.
4. Sight your picture through viewfinder. Make sure camera is not tilted to right or left. Hold camera steady, elbows drawn in against sides, and gently depress release button until shutter clicks.

DEPTH OF SHARPNESS SCALE



LENS DIAL



FOCUSING DIAL (feet)



# DAYLIGHT EXPOSURE GUIDE

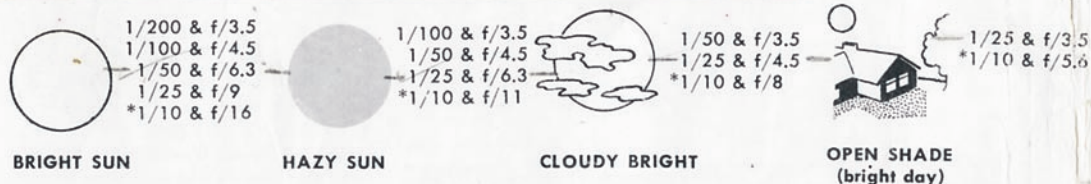

\*Exposures longer than 1/25 second require use of a tripod and cable release to avoid blur due to camera movement.

Any combination of shutter and lens setting found in given column can be used when you have the light condition for that column. This guide is based on average subject matter, containing equal portions of light and dark areas. For scenes that are predominantly light or dark, see next page.

If you want to catch an action scene, select a relatively fast shutter speed. If you want

depth of focus in a scene use a small lens opening (high f/ number). More detailed instructions can be found in sections on Stopping Action and Focusing in the following pages. This exposure guide is computed for the Stereo Colorist camera and Kodachrome film, daylight type, or Kodachrome film, Type A, using daylight conversion filters.

# TYPES OF SUBJECTS

Exposures for average subjects are provided in the guide on the previous page. Light subjects require less exposure. Dark ones call for more.



**LIGHT SUBJECTS** (the beach, snow or water scenes) require less exposure. For less exposure, use the next highest f/ number for shutter speed you choose in exposure guide on page 10. Example: 1/50 & f/8 instead of 1/50 & f/6.3.



**AVERAGE SUBJECTS** contain things of medium brightness, or approximately equal parts of extremely light and dark colors. The basic exposure guide is for material of this type. Use it whenever you are in doubt about how a scene should be classed.



**DARK SUBJECTS** including people in dark clothing, dark foliage, animals, and buildings require more exposure (smaller f number) than average subjects. If average scene calls for 1/50 at f/6.3 dark scene in same light will require 1/50 at f/4.5.

**NOTE:** If the exposure selected in the guide happens to fall on an aperture number that is marked on the lens dial, compensate for a light subject by using the next higher marked number, for a dark one by using the next lower marked number. If it falls between marked numbers, use the next higher or lower space between numbers.

# FOCUSING

The Stereo Colorist has f/3.5 Rodenstock Stereo-Trinar lenses—famous for taking critically sharp pictures. When you focus the camera for objects at a given distance they come out brilliantly clear. Things much nearer the camera and farther away appear sharp, too. You can get great depth of focus whenever you desire.

FOCUS AT f/6.3



To help you make best use of this lens quality the Stereo Colorist is equipped with a depth of sharpness (depth of focus) scale. When you have focused the camera on a given object, this scale shows at a glance the nearest and farthest objects that will appear sharp in the picture.

The illustration below shows how the depth of sharpness scale indicates what will appear sharp in a picture taken with the sunny-day settings—lens midway between f/5.6 and f/8, shutter at 1/50 second and focusing dial at 24 feet. Examples covering

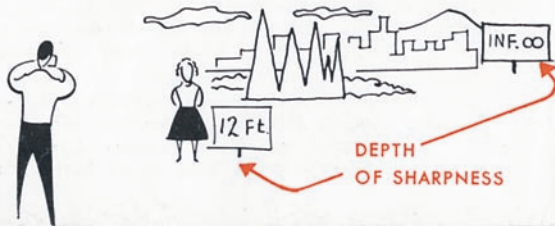

other picture situations are shown on the pages that follow.

The illustration below shows how to obtain sharpness from 6 feet to infinity. The lens is set at f/11, and the focusing dial is set at 12 feet. All the different distances between 6 feet and infinity on the focusing dial fall between the two f/11 marks on the depth of sharpness scale. This means that everything from 6 feet to infinity will appear sharp in the picture. Small lens openings call for slow shutter speeds and it is advisable to use a tripod in order to avoid blur

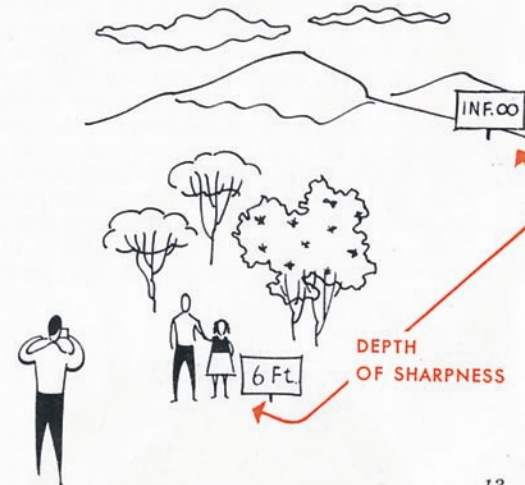

sometimes caused by camera movement.

If a scene does not require great depth of focus, you can use relatively large lens openings and still have a sharp picture. This is a good trick to use when you don't have a tripod handy, or don't want to use a slow shutter speed because of possible subject movement.

Here the scene contains subject matter from 6 to 12 feet that you want sharp, and we assume that you will use the basic, hand-held camera settings of 1/50 at f/6.3 for average subjects on sunny days. The prob-

lem is to set the focusing dial so everything will be sharp from 6 to 12 feet. The way to solve it is to turn the focusing dial until 6 feet is aligned midway between f/5.6 and f/8 on the depth of sharpness scale. We know the sharpness range includes everything in the picture. If you want more distant objects in focus, a smaller lens opening must be used. If the range of distances is less than that provided by the lens opening selected, it should be centered within the depth of sharpness available as shown on the next page.

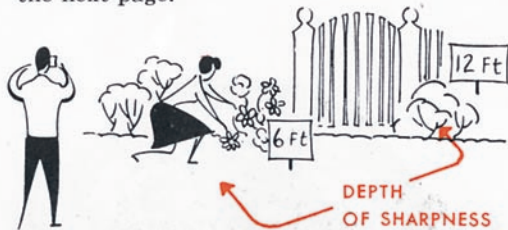

## FOCUSING — FOR THE CRITIC

If you use the depth of sharpness scale and keep subject matter within the range it indicates you will get pictures that are superbly sharp. If you want to gild the lily, the Stereo Colorist's Stereo-Trinar lenses will give you even better results. Just focus so as to use only the central portion of the depth of sharpness indicated on the scale.

This procedure is desirable whenever the exposure settings you choose provide more depth than the scene requires. In the example, a lens opening of f/8 provides more

sharpness than the scene needs. At one extreme you could place infinity on the focusing dial opposite f/8 on the depth of focus scale, to provide depth from infinity to about 7 feet. At the other extreme you could place 12 feet opposite f/8 to get depth from 12 feet to infinity. The best solution, as shown, is to center the focus setting between these two extremes. Pictures made this way will satisfy even the most severe critic. To perfect this technique, use your own camera and experiment with the different possible settings for this picture situation.



## STOPPING ACTION

The Gauthier shutter of your Stereo Colorist provides a wide range of speeds. Moving things may be blurred in pictures if your shutter speed is not fast enough. On the other hand, it is undesirable to shoot faster than necessary. High shutter speeds require wide lens openings to obtain sufficient exposure. On preceding pages we have seen that smaller lens openings provide greater depth of sharpness. The photographer must weigh the advantages of fast shutter speeds against small lens openings to see which are more important in each picture situation. At right are the speeds possible with the Stereo Colorist.



**BULB**—Used for time exposures. Requires tripod and cable release. Scenes must be perfectly still. Beware waves and wind-blown foliage. Don't show people near camera.



**1/10**—Longest automatically-timed exposure. Requires tripod and cable release. Scenes must appear still. Avoid people, animals or anything that moves, particularly near the camera.



**1/25**—Slowest shutter speed that can be used for hand-held pictures. Requires extreme care to avoid moving camera while tripping shutter. Good for posed pictures of people and slight movement for a distance from camera.



**1/50**—Recommended for flash pictures and for general use outdoors on bright days. Catches distant action like cattle grazing, sailboats, pedestrians incidental to street scenes and waves breaking on shore.



**1/100**—Catches moderately fast action near the camera, fast action at a distance. Suitable for children playing outdoor games, moving traffic and pedestrians in street scenes.



**1/200**—Top speed of the Stereo Colorist. Captures sports action near the camera, showing runners and jumpers with sharpness except when the fastest movement is directly across the camera's field of view.

**CAMERA MOVEMENT** causes more blurred pictures than anything else. Don't jar the camera as you trip the shutter. Use 1/25 second or faster, press elbows in against sides, and hold your breath for an instant as you gently squeeze down the shutter release. Never jab at it sharply.

**TIMING** and angle are as important as a fast shutter. Shoot movement to or from the camera, not right across in front of it. Watch for moments when action pauses, as at the peak of a dive or a dancer's leap into the air, and try to time your picture to capture these peaks.

## PICTURE PROBLEMS

The Exposure Guide on page 10 shows that several different combinations of lens opening and shutter speed will give exactly the same exposure under any given set of lighting conditions. Which should you use? Small lens openings (larger f/ numbers) give greater depth. Fast shutter speeds stop movement, but they also limit the depth of sharpness, because they require a large lens opening. So if you want speed you can't have great depth of focus, and vice versa. These examples are planned to help you decide when to favor one or the other, and when to compromise between them.

**EXTREME DEPTH** demands small lens openings, which in turn require slow shutter speeds to give sufficient exposure. Here, with light subject matter and bright sunlight, 1/10 second and f/16 would give you excellent results. The camera should be mounted on a tripod.

1/10 & f/16



**AVERAGE SCENES** usually permit a compromise between small lens openings and fast shutter speeds. The basic 1/50 second and f/6.3 exposure gives depth from 12 feet to infinity and avoids blur due to slight subject movement, while permitting the photographer to hold the camera in his hands.

1/50 & f/6.3



**MODERATE MOVEMENT** in a scene with considerable depth calls for a compromise in favor of a higher shutter speed. Here the exposure is 1/100 second with lens at f/4.5. This lens opening provides sharpness from about 20 feet to infinity. At this setting, objects closer than 20 ft. will not be sharp.

1/100 & f/4.5



**FAST ACTION** means top shutter speeds, which dictate wide lens openings for proper exposure. You can't get extreme depth and fast action in the same picture. One solution is to shoot from a low position, aiming the camera upward and outlining the subject against the sky. This trick eliminates the need for great depth.

1/200 & f/3.5



## STEREO COLORIST FLASH

You are free to take pictures at any time or place, day or night, indoors or out, with a Stereo Colorist flash unit mounted on your camera. It is scientifically designed to avoid the "pink eye" effect sometimes observed in stereo pictures of people, made with other flash equipment. Its test lamp glows when you insert a flashbulb, showing at a glance that the lamp is o.k. and the batteries have proper strength. You will find your flash unit of great use in eliminating undesirable facial shadows on bright sunny days.

1. Mount the unit on your camera by slipping the shoe on its base into the flash mount. Seating the shoe in the mount automatically makes the necessary electrical connection. Set the shutter dial at 1/50 second.

2. Insert the flashbulb, pressing it firmly into the socket.

3. Align the subject in the camera viewfinder, moving backward or forward to take in as much area as you want to show in the picture.

4. Estimate the distance from camera to subject. If you are photographing a group or covering a deep area, select a point halfway between the nearest and farthest important subjects. Set the focusing dial for this distance.

5. Use the table on the next page to determine what lens opening to use for the distance at which the picture will be taken. Set the lens dial accordingly.

6. Take the picture by aligning the subject in the viewfinder and pressing the shutter release in the usual manner. Remember to hold camera straight and steady.

**CAUTION:** Flashbulbs have a transparent plastic coating designed to keep them from breaking when fired. If this coating becomes damaged in handling they may shatter. For protection, use of a plastic flash shield over the reflector is recommended. Several types, all inexpensive, can be purchased from your photo dealer.

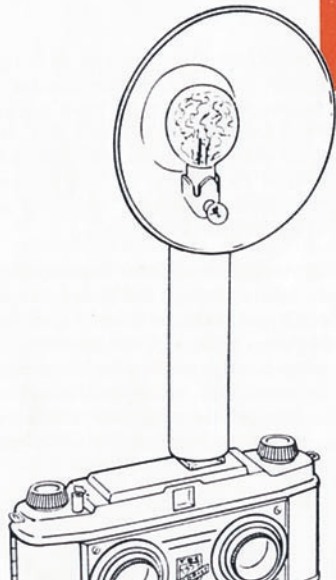

## FLASH EXPOSURE

The table at the right is for SM and SF bulbs used with Kodachrome Type A, and for 5B and 25B bulbs used with Daylight Kodachrome. It is based on average subjects, photographed in a room whose walls and ceiling reflect an average amount of light. Pictures of dark subjects taken outdoors at night, or in very large rooms, or rooms with dark walls, will require larger lens openings to compensate for the lack of reflected light. Pictures of very light subjects in small rooms with light walls call for smaller lens openings.

FLASH TABLE	
Feet	Lens
3	f/16
4	f/11
6	f/8
8	f/5.6
12	f/4
15	f/3.5

**NOTE:** Things at distances indicated will be properly exposed, but the light penetrates much farther. Nearer objects will appear somewhat light, farther ones darker than normal. To avoid wide differences in lighting it is best to keep important subjects fairly close to the same distance from the camera.



### SM-SF.

These lamps and Kodachrome Type A film provide the ideal combination for most flash pictures. They require no filters. The lamps give an instantaneous flash, burning so fast that they provide the equivalent of 1/200 second shutter speed even though the shutter dial itself is actually set at 1/50.



### 5B-25B.

These blue tinted lamps are made for use with Daylight Kodachrome film and require no filters when employed with it. They can be used as the sole light source for indoor and night pictures, or as "fill-in" light to illuminate shadows in pictures taken by sunlight.

## WHICH FILM IS BEST?

That depends on what you want to do. If you plan on taking outdoor photos, with only an occasional flash shot, load the camera with Daylight type film. Then you can use blue bulbs when you need flash. If you expect to take a lot of flash shots, load with Type A film and use SM or SF bulbs. To take daylight pictures while the camera is loaded with Type A film, place a pair of Type A Filters (No. 85) over the camera lenses.

# STEREO PLANNING

Taking pictures in 3-D differs little from ordinary photography except that it is easier to get breath-taking results. These points will help you take superb pictures:

**LEVEL** the camera for every shot, paying particular attention to vertical lines such as trunks of trees or sides of buildings. The camera can be pointed up or down, but do not tilt it.



THIS . . .



NOT THIS



**FOCUS** sharply. The beautiful realism of stereo is more convincing when pictures are razor-sharp. Use the depth of sharpness scale to make sure entire scene will be sharp. And hold camera steady so it doesn't move when you trip the shutter.

Pictures that are not too deep project best on a big screen. Most pictures project well when properly mounted. But, if you want your slides to conform to critical standards, plan your pictures to fall within the distance ranges covered by projection mounts:

- Normal—7 feet to infinity
- Medium—4 to 18 feet
- Closeup—2½ to 6 feet

**LIGHTING** should be flat and from the front for most effective stereo shots, and of course, sparkling sunlight is best. Shoot with the sun behind you, shining over your shoulder. Avoid backlighted subjects, deep shadows, and large shadow areas.



**FOREGROUND** material gives depth effect. Show a person or object somewhere within 7 to 20-foot distance range of every picture, even if the main subject is much farther away. Overhanging branches, archways and big rocks are just some of the foreground objects you can use.

## PRECISION MATCHED ACCESSORIES FOR YOUR TDC STEREO COLORIST CAMERA



### TDC Stereo Vivid Projector

Takes Stereo Colorist and all 35-mm stereo slides, and standard 2x2 slides. Matched, coated f/3.5 anastigmat lenses, twin 500-watt light systems. Requires polarizing glasses.

with 5" lenses	with 4" lenses	carrying case
\$169.50	\$179.50	\$20.00



### TDC Stereo Vivid Viewer \$17.50

A handy, compact viewer with superb brilliance. Takes all standard 1 5/8 x 4 stereo slides. Dual focusing knobs, smooth interocular control, precision achromatic lenses with larger apertures for bigger picture.

Also available — Tray-loading Stereo Selectron Changer for either projector, \$19.50.



### TDC Stereo Project-or-View

Both viewer and projector. Big 45 1/2 sq. in. black glass screen. Matching 3" f/2.8 coated anastigmat lenses, condensers, polarizers. Twin 300-watt lamps. Takes all standard stereo slides and 2x2 slides (non-stereo). AC only.

\$144.50	carrying case
tax included	\$20.00

(Prices subject to change without notice. July, 1954).

## WARRANTY

1. This new TDC Stereo Colorist Camera is warranted for a one-year period from the date of purchase thereof to be free from defects in materials and workmanship. Any servicing necessary because of imperfections in materials or workmanship during such one-year period will be performed without charge (except for transportation of camera) by Three Dimension Company division of Bell & Howell.

2. A camera which has been damaged or abused or which has become worn from extended use will be repaired at factory-established rates.

3. No liability is assumed for expenses or damages resulting from interruptions in operation of the camera.

4. The Company will not be liable for damage to camera during transit when said camera is being returned for service under this warranty.

5. This guarantee is void: (a) if camera has been serviced by other than TDC; (b) if camera has not been registered with TDC within 10 days from date of purchase thereof (use card attached).

6. This warranty is made in lieu of any other warranty, guarantee or liability, expressed or implied. It is valid only as to the initial purchaser of this new camera and his donees.

THREE DIMENSION COMPANY  
division of Bell & Howell

**THREE DIMENSION COMPANY**  
division of **BELL & HOWELL**

FORM 15679

Printed in U.S.A.